

B.R. PRECISION SELF CENTERING VICE



Model Type: BR SCV-90-110-180-250

Trouble Free Performance

Mechanically Operated

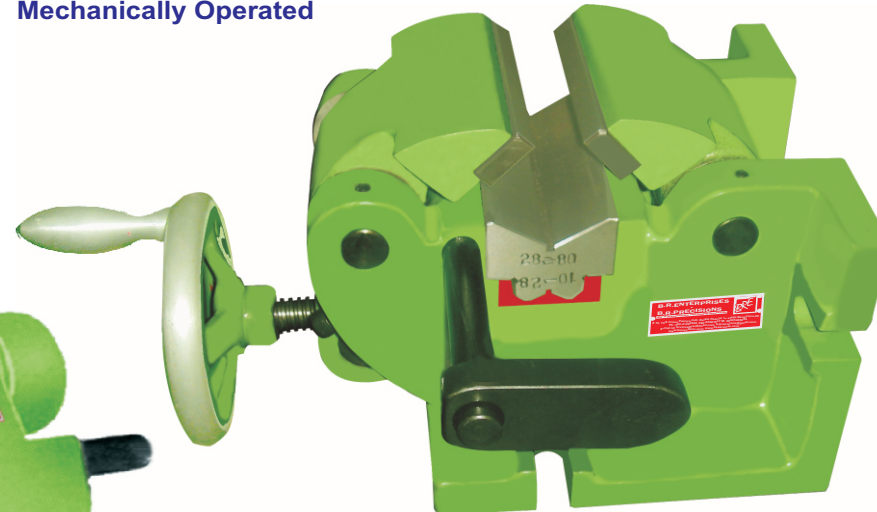

Description

B.R. Precision Self Centering Vice for Round Dia Holding
 The base is made of graded Steel cast iron. All components are machined to close tolerance.
 The base is Ground guarantee perfect squareness.
 'V' Blocks are made out of tool steel hardened and ground and have two V shaped locations. By simply reversing the 'V' Block the clamping range can be enhanced.
 Clamping jaws are also made out of tool steel hardened and ground.
 All parts are perfectly interchangeable in this Vice.
 Stopper Shaft attached for Any Length of Dimension for making any kind of machining Work Piece

B.R. PRECISION SELF CENTERING VICES



Round dia Holding

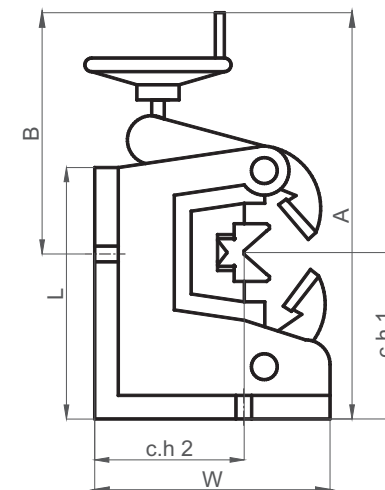
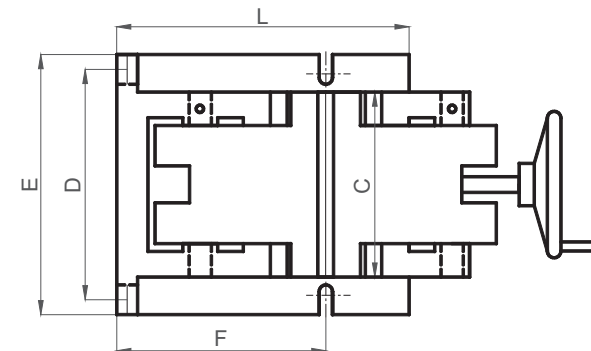

Model Types. & Dimensions

Mechanically Operated

Specification	Model Type BR-SCV 90	Model Type BR-SCV 110	Model Type BR-SCV 180	Model Type BR-SCV 250
Diameter Range	6 to 50 mm	10 to 80 mm	50 to 150 mm	100 to 250 mm
Width of jaws (C)	90 mm	110 mm	180 mm	250 mm
Vertical base (L x W)	150 x 140 mm	185 x 150 mm	270 x 185 mm	400 x 250 mm
Horizontal base (L x E)	150 x 175 mm	185 x 200 mm	270 x 275 mm	400 x 360 mm
Overall Length with handle (A)	345 mm	415 mm	530 mm	715 mm
Over all Height at Maximum Open of Arm	145 mm	165 mm	295 mm	435 mm
Center Height of 'V' Block @ horizontal (c.h 2)	96 mm	130 mm	190 mm	280 mm
Center Height of 'V' block @ vertical (c.h 1)	90 mm	140 mm	180 mm	230 mm
P.C.D of Open Slot Cross (D)	147 mm	172 mm	243 mm	328 mm
P.C.D of Open Slot Longitudinal (F)	96 mm	130 mm	190 mm	280 mm
Length of Open Slot to Handle (B)	275 mm	280 mm	345 mm	425 mm
Tenon Slot	14mm	14mm	18 mm	18 mm
Weight (App)	18 Kg.	28 Kgs.	60 Kgs.	135 Kgs.

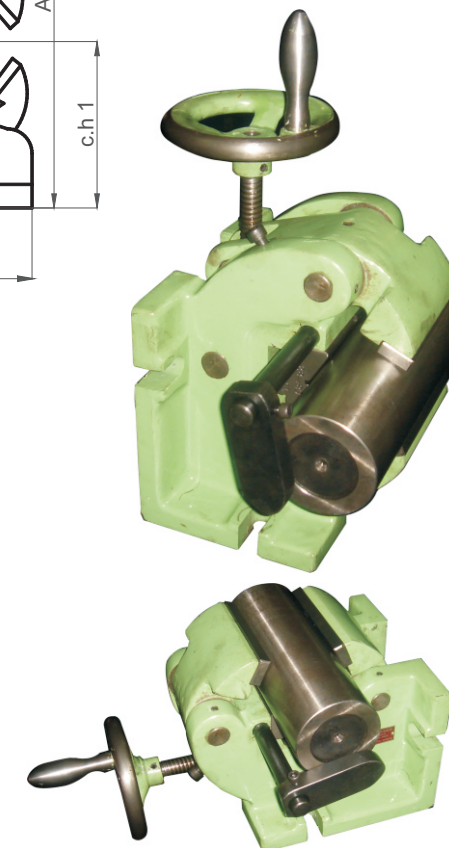

A view of Dia Holding Vice

Warranty: One year conditional warranty on manufacturing defects

Manufacturer: Sales Office : # 19, TVS CROSS, PEENYA INDUSTRIAL ESTATE I STAGE, BANGALORE - 560 058, INDIA
 MOB: +91 98452 08854, 094496 48171, 099726 37475, 08722472132
 E-mail Id: brvices@rediffmail.com, brprecisions@gmail.com



Visit us at: www.brprecision.com, www.brsvices.com

Visit us at www.brsvices.com, www.brprecision.com